



LOWER CONTROL ARM MONOBALL KIT INSTALLATION INSTRUCTIONS

PART NUMBER D280-0022

APPLICATION: 2019 - 2020 G20 M340i
2019 - 2020 G20 M340i xDrive
2019 - 2020 G20 330i
2019 - 2020 G20 330i xDrive

PARTS LIST

Quantity	Part #	Description
1	D281-0003	Loctite 609 Compound
2	D283-0035	Monoball & Carrier Assembly
2	D282-0058	Retaining Caps
10	D671-0035	M6x45 Stainless Screws
10	Z1001487	M6x50 Stainless Screws
4	D282-0057	Spacers

Congratulations for being selective enough to use a Dinan Engineering Monoball Kit. We have spent many hours developing this kit to assure that you will receive maximum performance and durability with minimum difficulty in installation. Please take the time to read these instructions and call us if you have any difficulties during the installation.

DO NOT WORK ON VEHICLES SUPPORTED BY A JACK ONLY. USE SECURE JACK STANDS!

INSTALLATION:

1. Remove the front Tension-Compression Arms, and press out the stock rubber bushing per BMW recommended procedure.
2. Measure the width of the control arm.
 - 32mm wide arms use the M6 x 45 bolts for assembly.
 - 36mm wide arms use the M6 x 50 bolts for assembly.

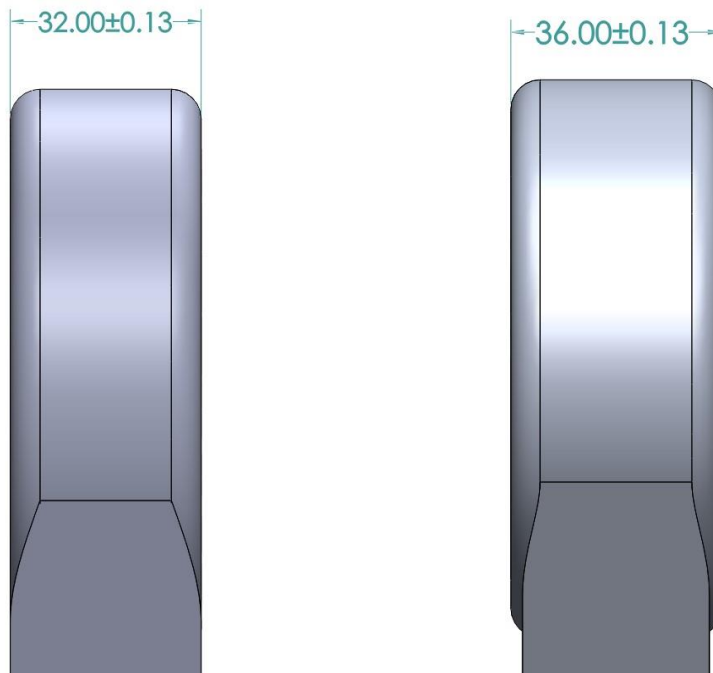

3. Clean out the bore with some soap and scotch-brite. The bore needs to be very clean and dry.
4. Apply a thin layer of Loctite 609 Retaining Compound (included in kit) to the outer bore of the Dinan monoball carrier. Use enough to cover most of the surface.

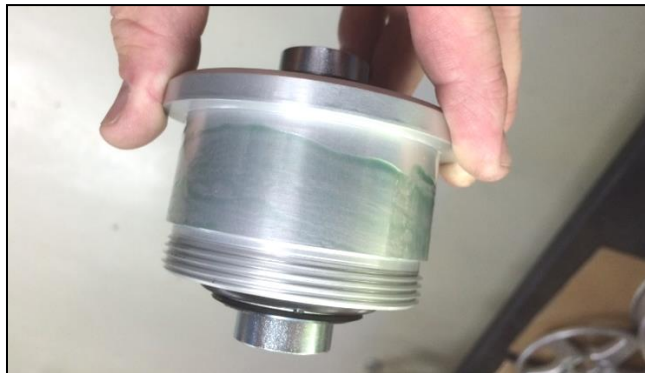

5. See figure below. Slide the carrier into the bore in the arm with a slight turning motion to further spread the Loctite around. It does not matter from which side of the arm you install the carrier, but it is preferred if both sides of the carrier shall sit flush against the surface of the control arm.

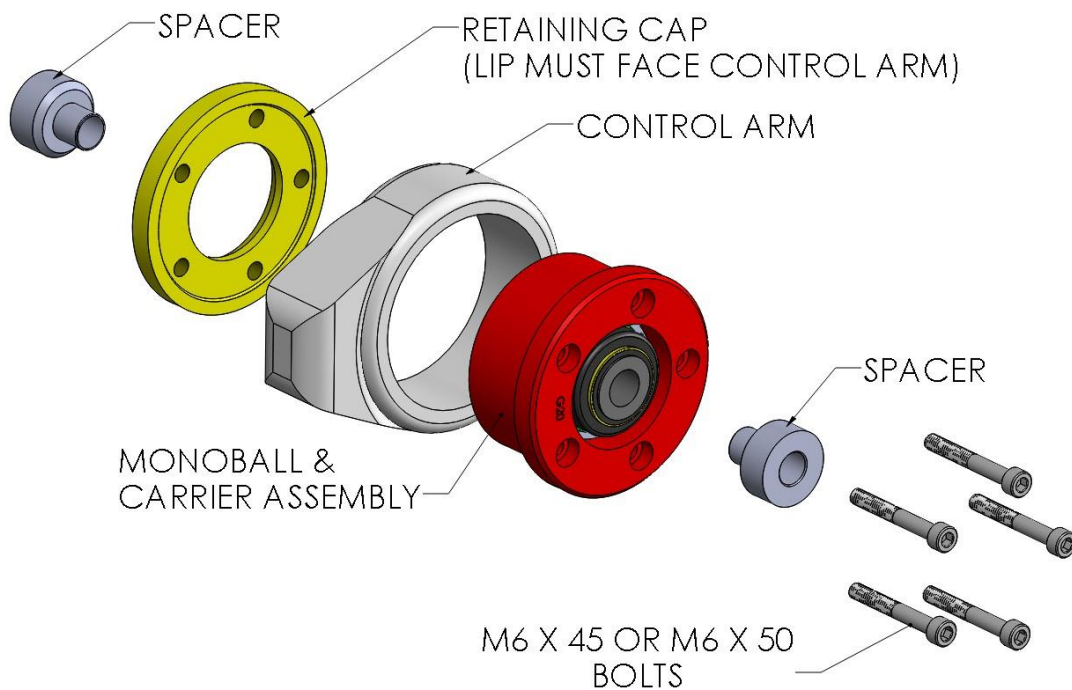

6. Install the Dinan retaining cap onto the arm (the lip must face the control arm as shown). Put a small amount of Loctite on the bolts and torque each to 95 inch-pounds to secure the retaining cap.
7. Install the Dinan bearing spacers as shown. These are intended to be a snug fit and may require a slight tap to seat fully.
8. Install the arms to the car using the stock bolts & nuts (replace as necessary).
9. Torque the bolts per BMW recommended procedure. NOTE: The monoball bolts must also be angle torqued per BMW specification!
10. Enjoy!